

K8055 voltage divider

The K8055 circuit has a maximum input voltage of 5 V. You can measure higher voltages but then you need to add a voltage divider. Generally, a voltage divider is formed by two resistors. Their value will determine the the attenuation.

The image below shows the analog input circuit of the K8055, with an additional external voltage divider. The external resistors are R_{ext1} and R_{ext2} .

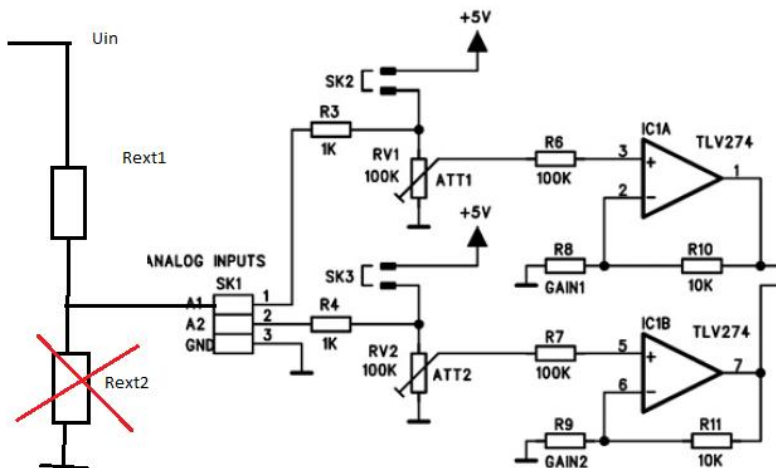

I have chosen not to use the R_{ext2} . In first instance this might look strange to you, but you need to keep in mind the K8055 circuit already has an internal resistor network. This network is formed by the resistor R_3 and the trimmer RV_1 . Their value are adding up to 101 k Ω .

This means the R_{ext1} is placed in series with the RV_1+R_3 . These two resistors can actually replace the role of the external resistor R_{ext2} .

Constructing the formula

We know the maximum input voltage at connector SK1 is 5 V, this value is given in the specifications of the board. This value should never be exceeded as you could damage the K8055 circuit.

So if we want to measure higher input voltages (U_{in}), we need to make sure the voltage at connector SK1 never exceeds 5 V. This leads to the following conclusion:

$$U_{R_{ext1}} = U_{in} - 5 V$$

This means the R_{ext1} should create a voltage drop of $U_{in}-5 V$.

First we will draw a simplified schematics of the voltage divider. In this schematic the R_{inp} represents the input resistance of the K8055 board ($R_{V_1}+R_3$).

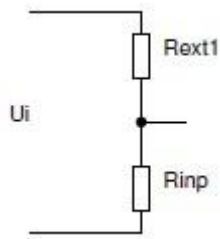

When powered by a certain input voltage, an electric current will flow through both resistors. The current through each resistor is the same (resistors in series). So we can write out the following equation:

$$\frac{U_{R_{ext1}}}{R_{ext1}} = \frac{U_{inp}}{R_{inp}}$$

We really want to find the value of the resistor R_{ext1} so we extract it from the formula:

$$R_{ext1} = \frac{U_{R_{ext1}} \times R_{inp}}{U_{inp}}$$

We now replace the $U_{R_{ext1}}$ by the formula we found earlier:

$$R_{ext1} = \frac{(U_i - 5V) \times R_{inp}}{U_{inp}}$$

Now we suppress the brackets:

$$R_{ext1} = \frac{U_i \times R_{inp} - 5V \times R_{inp}}{U_{inp}}$$

Now we see that the numerator and denominator have something in common (R_{inp}/U_{inp}). We place them outside the fraction:

$$R_{ext1} = \frac{R_{inp}}{U_{inp}} \times (U_i - 5V)$$

We know R_{inp} is the sum of $R_{V1}+R_3$, the input resistance of the K8055 board. So we write this out in the formula. This results in our final formula:

$$R_{ext1} = \frac{R_{v1} + R_3}{U_{inp}} \times (U_i - 5V)$$

In this formula we have the following variables:

- R_{v1} : value of the trimmer (100 k Ω).
- R_3 : value of the resistor (1 k Ω).
- U_{inp} : maximum input voltage of the K8055 board (5 V)
- U_i : maximum voltage at the input of the voltage divider.

Simplification of the formula

This formula is rather "complicated" to work out on a calculator. So let's simplify it a little bit. We know the R_{V1} , R_3 and U_{inp} are fixed values. So we can replace it by a number:

$$\frac{R_{v1} + R_3}{U_{inp}} = \frac{100k + 1k}{5} = 20.2k$$

So our new formula would become:

$$R_{ext1} = 20.2k \times (U_i - 5V)$$

We can perform one more additional simplification: the value of R_{V1} is much larger than the value of R_3 . This means the influence of the resistor R_3 is almost negligible. We can just write:

$$R_{ext1} = 20k \times (U_i - 5V)$$

The resulting formula is surprisingly easy: we need to add an external 20k resistance for each volt above the maximum permitted input voltage of the K8055. It is easy to remember and easy to calculate with.

The other way: using a fully external voltage divider

I just explained we can take out the resistor R_{ext2} . Maybe you don't like that, and you want to use a full external voltage divider. No problem, but you shouldn't forget the effect of the internal resistors on the K8055 board.

The complete formula would then be:

$$R_{ext1} = \frac{\left(\frac{R_{ext2} \times (R_3 + R_{v1})}{R_{ext2} + (R_3 + R_{v1})} \right)}{U_{inp}} \times (U_i - 5V)$$

You can clearly see the formula now involves the R_{ext2} . Its value can be chosen freely, but this should be done with care because it influences the equivalent input resistance of the K8055 board.

We could also ignore the effect of the internal resistance of the K8055 board. The formula would then be:

$$R_{ext1} = \frac{R_{ext2}}{U_{inp}} \times (U_i - 5V)$$

Using this formula would be fine as long as you use low values for the R_{ext2} . For example, you shouldn't use a resistance of 1 M for R_{ext2} . Let's assume you use two external resistors of 1 M Ω for R_{ext1} and R_{ext2} , and see what happens:

Theoretically this would result in a nice /2 voltage divider. But there is the effect of the internal resistance of the K8055, which is 101 k Ω . The equivalent resistance for R_{ext2} (R_{ext} in parallel with $R_{internal}$) would be 91 k Ω . So with an input voltage (U_i) of 10 V the voltage over the resistor R_{ext2} would only be 0.83 V, a value far from the "expected" 5 V.

The last formula is probably accurate enough for most applications. The advantage here is you can use lower resistor values. My previous formula required multiples of 20k values.